

TVAC 2.92mm Plug (Male) to 2.4mm Jack (Female) Straight Adapter,
DC-40 GHz, VSWR 1.25

VH-AD-K1Q25A / 9XX-9X

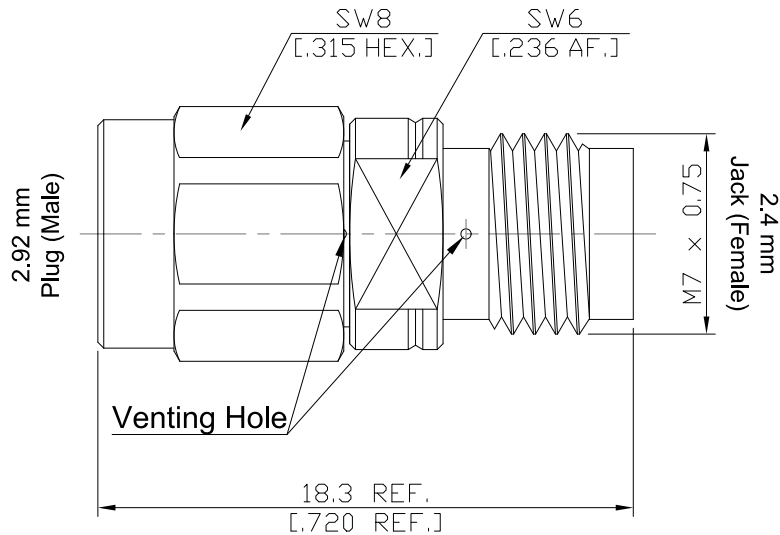

All dimensions are in mm [inch]

Tolerances according to DIN ISO 2768-mH

Interface

Mechanically compatible with
According to

2.92mm Side
3.5mm and SMA
IEC 61169-35, IEEE Std 287

2.4mm Side
1.85mm
IEC 61169-40, IEEE Std 287

Electrical Data

Impedance	50 Ω
Frequency	DC to 40 GHz
VSWR (Return Loss)	≤ 1.25 (≥ 19.08 dB)
Insertion Loss	$\leq 0.05 \times \sqrt{f}$ (GHz) dB
Insulation Resistance	≥ 5 G Ω
Test Voltage (at sea level)	500 V rms
Working Voltage (at sea level)	150 V rms
RF Leakage	≥ 100 dB up to 1 GHz
Power Handling	18W

-Vacuum Vented Construction for Thermal Vacuum Applications-

Material And Plating

Piece Parts (2.92mm)	Material	Plating
Centre Contact	Beryllium Copper	Gold plating (Non-magnetic nickel-phosphorus underplating)
Body	Stainless Steel	Passivated
Insulator	PEI	
Gasket	Silicone Rubber	
Coupling Nut	Stainless Steel	Passivated
Piece Parts (2.4mm)	Material	Plating
Centre Contact	Beryllium Copper	Gold plating (Non-magnetic nickel-phosphorus underplating)
Body	Stainless Steel	Passivated
Insulator	PEI	

TVAC 2.92mm Plug (Male) to 2.4mm Jack (Female) Straight Adapter,
DC-40 GHz, VSWR 1.25

VH-AD-K1Q25A / 9XX-9X

Mechanical Data

	2.92mm Side	2.4mm Side
Coupling mechanisms	Screw-On	Screw-On
Mating Cycles	≥ 500	≥ 500
Center Contact Captivation	≥ 20 N	≥ 20 N
Coupling Test Torque	1.70 Nm max.	1.65 Nm max.
Recommended Torque	0.80 Nm to 1.10 Nm	0.80 Nm to 1.10 Nm

Environmental Data

Temperature Range	-65°C to +165°C
Thermal shock	MIL-STD-202, Method 107, Condition B
Corrosion	MIL-STD-202, Method 101, Condition B
Vibration	MIL-STD-202, Method 204, Condition D
Shock	MIL-STD-202, Method 213, Condition I
Moisture Resistance	MIL-STD-202, Method 106
Low outgassing	TML ≤ 1.0%, CVCM ≤ 0.1%
Vacuum Pressure	≤ 1 × 10 ⁻⁵ Torr
RoHS	compliant

Packing

Standard	Single or 100
----------	---------------