

1.85mm Jack (Female) to 3.5mm Jack (Female) Adapter
DC-33 GHz VSWR1.15

AD-V2PC25A / 9X-9X

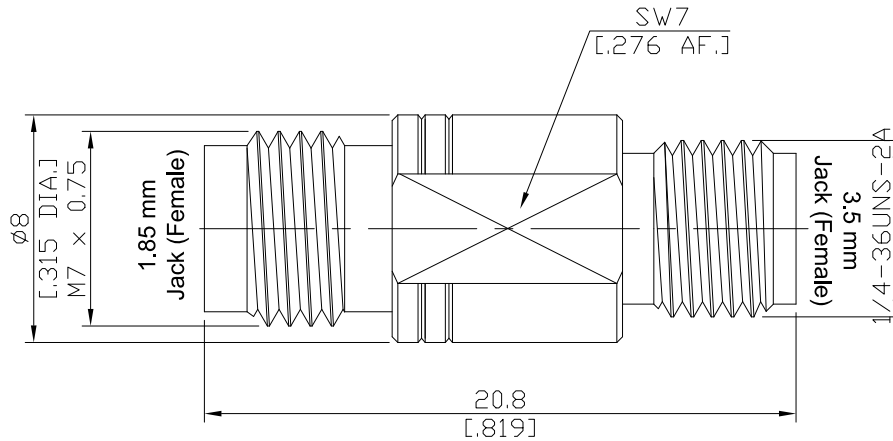

All dimensions are in mm [inch]
Tolerances according to DIN ISO 2768-mH

Interface

1.85mm According to	IEC 60169-32; IEEE Std 287
Mechanically compatible with	2.4mm
3.5mm according to	IEC 60169-23; IEEE Std 287
Mechanically compatible with	2.92mm, SMA

Electrical Data

Impedance	50 Ω
Frequency	DC to 33 GHz
VSWR (Return Loss)	≤ 1.15 (≥ 23.13 dB)
Insertion Loss	≤ 0.05 x √F (GHz) dB
Insulation Resistance	≥ 5 GΩ
Test Voltage (at sea level)	500 V rms
Working Voltage (at sea level)	150 V rms
RF Leakage	≥ 100 dB up to 1 GHz

Material And Plating

Piece Parts (1.85mm)	Material	Plating
Centre Contact	Beryllium Copper	Gold plating (Non-magnetic nickel-phosphorus underplating)
Body	Stainless Steel	Passivated
Insulator	PEI	
Piece Parts (3.5mm)	Material	Plating
Centre Contact	Beryllium Copper	Gold plating (Non-magnetic nickel-phosphorus underplating)
Body	Stainless Steel	Passivated
Insulator	PEI	

1.85mm Jack (Female) to 3.5mm Jack (Female) Adapter
DC-33 GHz VSWR1.15

AD-V2PC25A / 9X-9X

Mechanical Data

	1.85mm Side	3.5mm Side
Coupling mechanisms	Screw-lock	Screw-lock
Mating Cycles	≥ 500	≥ 500
Center Contact Captivation	≥ 20 N	≥ 20 N
Coupling Test Torque	1.65 Nm max.	1.70 Nm max.
Recommended Torque	0.80 Nm to 1.10 Nm	0.80 Nm to 1.10 Nm

Environmental Data

Temperature Range	-55°C to +165°C
Thermal shock	MIL-STD-202, Method 107, Condition B
Corrosion	MIL-STD-202, Method 101, Condition B
Vibration	MIL-STD-202, Method 204, Condition D
Shock	MIL-STD-202, Method 213, Condition I
Moisture Resistance	MIL-STD-202, Method 106
RoHS	compliant

Packing

Standard	Single or 100
----------	---------------