

SMPM Jack (Female) to SMPM Jack (Female) Bullet Adapter, .300 inch Length  
DC- 50 GHz , VSWR 1.5

**AD-PM2PM25A-BL7.62 / 99-99**

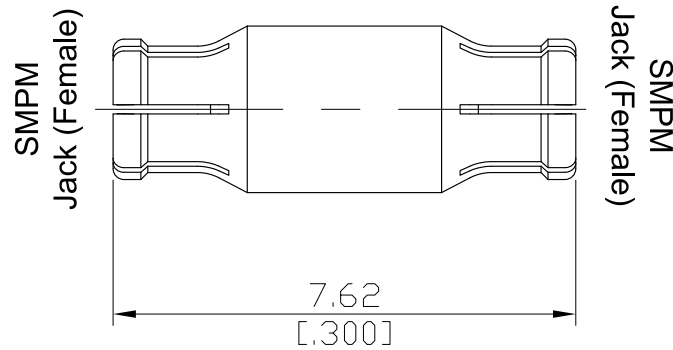

All dimensions are in mm [inch]

Tolerances according to DIN ISO 2768-mH

**Interface**

According to MIL-PRF-31031; MIL-STD-348B/328

**Electrical Data**

Impedance	50 Ω	
Frequency	DC to 50 GHz	
VSWR (Return Loss)	≤ 1.15 (≥ 23.13 dB), DC to 18.0 GHz	
	≤ 1.50 (≥ 13.98 dB), 18.0 to 50.0 GHz	
Insertion Loss	≤ 0.1 × √F (GHz) dB	
Insulation resistance	≥ 5 GΩ	
Center contact resistance	≤ 6 mΩ	
Outer contact resistance	≤ 2 mΩ	
Working voltage	325 V rms (at sea level)	125 V rms (at 70000 feet)

**Material And Plating**

Piece Parts (SMPM)	Material	Plating
Centre contact	Beryllium Copper	Gold plating (Non-magnetic nickel-phosphorus underplating)
Body	Beryllium Copper	Gold plating (Non-magnetic nickel-phosphorus underplating)
Insulator	PTFE	
Piece Parts (SMPM)	Material	Plating
Centre contact	Beryllium Copper	Gold plating (Non-magnetic nickel-phosphorus underplating)
Body	Beryllium Copper	Gold plating (Non-magnetic nickel-phosphorus underplating)
Insulator	PTFE	

SMPM Jack (Female) to SMPM Jack (Female) Bullet Adapter, .300 inch Length  
DC- 50 GHz , VSWR 1.5

**AD-PM2PM25A-BL7.62 / 99-99**

**Mechanical Data**

Coupling mechanisms	Snap-lock	
Mating cycles	Full detent: ≥ 100	Smooth bore: ≥ 500
Center contact captivation: axial	≥ 7 N	
Engagement force	Full detent: 19 N typical	Smooth bore: 11 N typical
Disengagement force	Full detent: 29 N typical	Smooth bore: 11 N typical

**Environmental Data**

Temperature Range	-65°C to +165°C
Thermal shock	MIL-STD-202, Method 107, Condition B
Vibration	MIL-STD-202, Method 204, Condition A
Shock	MIL-STD-202, Method 213, Condition A
Moisture resistance	MIL-STD-202, Method 106
RoHS	compliant

**Packing**

Single or 100