

2.92mm Female Connector Attachment End Launch PCB, Removable End Launch,
Low Profile, Thick Board 5.3mm (.210)

K2HA50-1892C2-LP / 9X

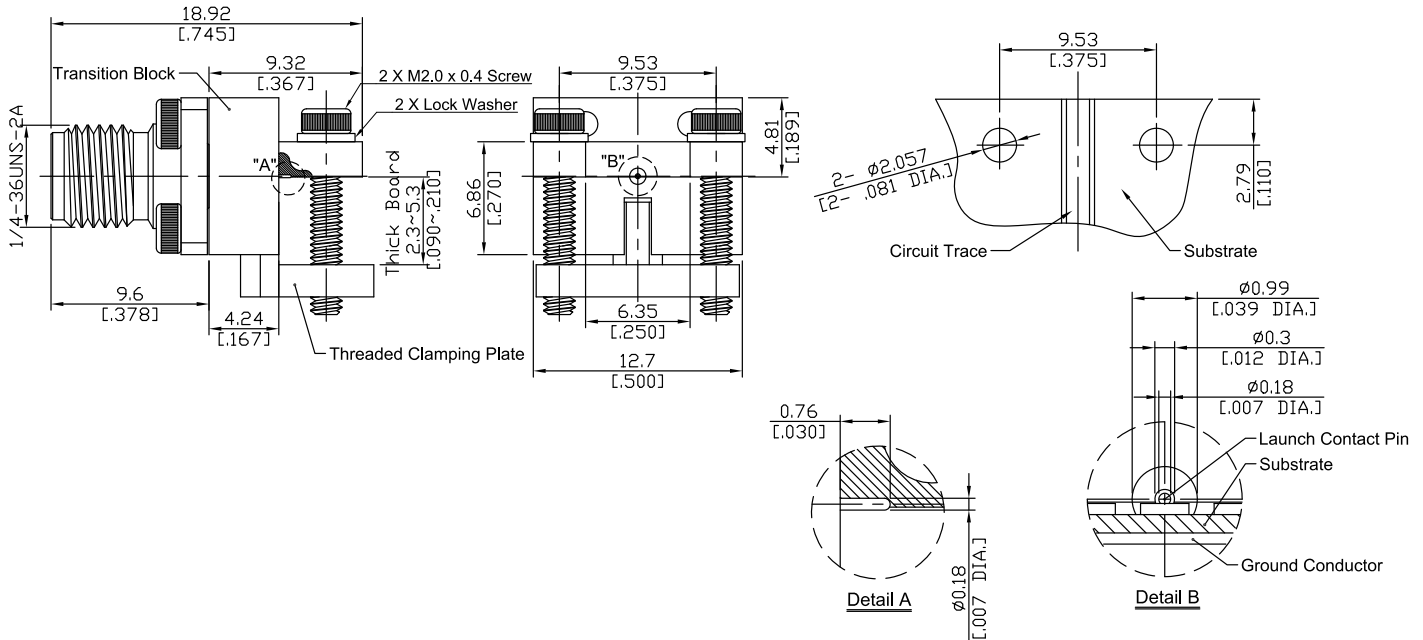

All dimensions are in mm [inch]
Tolerances according to DIN ISO 2768-mH

Interface

According to IEC 61169-35; IEEE Std 287

Electrical Data

Impedance	50 Ω
Frequency	DC to 40 GHz
VSWR (Return Loss)	≤ 1.40 (≥ 15.56 dB)
Insertion Loss	≤ 0.04 × √F (GHz) dB
Insulation Resistance	≥ 5 GΩ
Test Voltage	750 V rms
Working voltage	250 V rms
RF-leakage	≥ 100 dB up to 1 GHz

Material And Plating

Piece Parts (2.92mm)	Material	Plating
Centre contact	Beryllium Copper	Gold plating (Non-magnetic nickel-phosphorus underplating)
Body	Stainless Steel	Passivated
Insulator	PEI	
Piece Parts (Transition Block)	Material	Plating
Launch Pin	Beryllium Copper	Gold plating (Non-magnetic nickel-phosphorus underplating)
Transition Block	Brass	Copper-Tin-Zinc Alloy
Transition Block Insulator	PTFE	

2.92mm Female Connector Attachment End Launch PCB, Removable End Launch,
Low Profile, Thick Board 5.3mm (.210)

K2HA50-1892C2-LP / 9X

Mechanical Data

Coupling mechanisms	Screw-lock
Mating Cycles	≥ 500
Center Contact Captivation: axial	≥ 20 N
Coupling Test Torque	1.65 Nm
Recommended Torque	0.80 Nm to 1.10 Nm

Environmental Data

Temperature Range	-65°C to +165°C
Corrosion	MIL-STD-202, Method 101, Condition B
Vibration	MIL-STD-202, Method 204, Condition D
Shock	MIL-STD-202, Method 213, Condition I
Moisture Resistance	MIL-STD-202, Method 106
RoHS	compliant

Packing

Single or 100