

SMA R/P Jack (Female) Straight Bulkhead Connector Crimp/Contact  
Pin Solder or Crimp Attachment for RG316D DC-6GHz VSWR1.25

**SMA7CA50-D316A / 11**

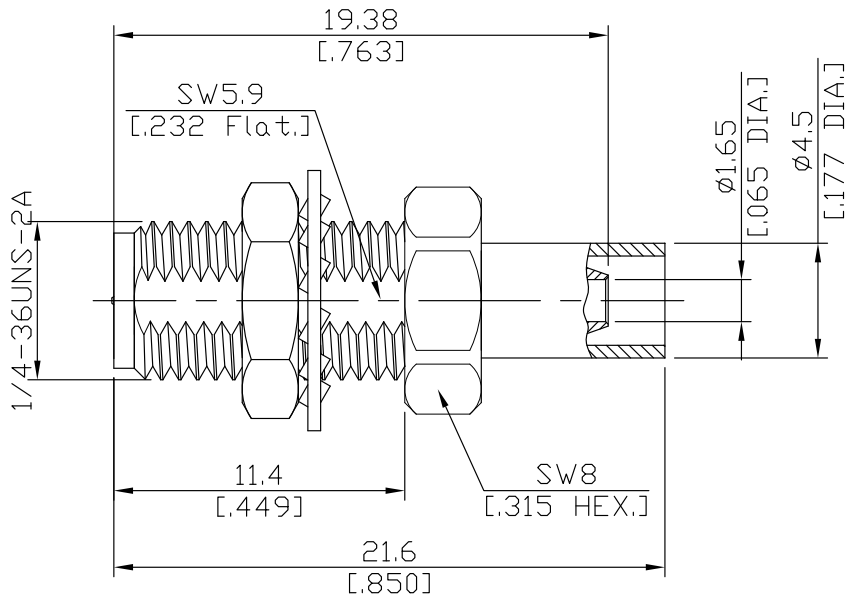

Mounting Dimension

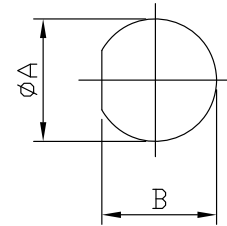

	mm		inch	
	Max.	Min.	Max.	Min.
A	6.5	6.4	.256	.252
B	6.15	6.0	.242	.236

All dimensions are in mm [inch]  
Tolerances according to DIN ISO 2768-mH

**Interface**

According to IEC 60169-15; CECC 22110; MIL-PRF-39012; MIL-STD-348B/310; EN 122110

**Electrical Data**

Impedance	50 $\Omega$
Frequency	DC to 6 GHz
VSWR (Return Loss)	$\leq 1.25$ ( $\geq 19.08$ dB)
Insertion Loss	$\leq 0.04 \times \sqrt{F}$ (GHz) dB
Insulation Resistance	$\geq 5$ G $\Omega$
Center contact resistance	$\leq 3$ m $\Omega$
Outer contact resistance	$\leq 2$ m $\Omega$
Test Voltage (at sea level)	1000 V rms
Working Voltage (at sea level)	480 V rms
Power handling	$\leq 200$ W @ 2 GHz
RF Leakage	$\geq 100$ dB up to 1 GHz

-VSWR in application depends decisive on cable assembly process-

**Material And Plating**

Piece Parts	Material	Plating
Centre Contact	Brass	Gold plating (Non-magnetic nickel-phosphorus underplating)
Body	Brass	Gold plating (Non-magnetic nickel-phosphorus underplating)
Insulator	PTFE	
Washer	Brass	Gold plating (Non-magnetic nickel-phosphorus underplating)
Fastening nut	Brass	Gold plating (Non-magnetic nickel-phosphorus underplating)
Crimp ferrules	Brass	Gold plating (Non-magnetic nickel-phosphorus underplating)

The facts and figures herein are carefully compiled to the best of our knowledge, but they are intended for general informational purposes only. In the effort to improve our products, we reserve the right to make changes judged to be necessary.

Rev.:-	Rosnol RF/Microwave Technology Co., Ltd. <a href="http://www.rosnol.com">www.rosnol.com</a> ; <a href="mailto:info@rosnol.com">info@rosnol.com</a>
Date: SEP/08/2025	Phone: +886-3-463-5095 / Fax: +886-3-463-5952 N-CAGE Code: SFKK0 / ISO9001 Certified

SMA R/P Jack (Female) Straight Bulkhead Connector Crimp/Contact  
Pin Solder or Crimp Attachment for RG316D DC-6GHz VSWR1.25

**SMA7CA50-D316A / 11**

**Mechanical Data**

Coupling mechanisms	Screw-lock
Mating Cycles	≥ 500
Coupling Nut Retention	≥ 270 N
Centre contact	Soldered
Cable entry	Crimped
Center Contact Captivation: axial	≥ 27 N
Coupling Test Torque	1.70 Nm max.
Recommended Torque	0.8 Nm to 1.1 Nm

**Environmental Data**

Temperature Range	-65°C to +165°C
Thermal shock	MIL-STD-202, Method 107, Condition B
Corrosion	MIL-STD-202, Method 101, Condition B
Vibration	MIL-STD-202, Method 204, Condition D
Shock	MIL-STD-202, Method 213, Condition I
Moisture Resistance	MIL-STD-202, Method 106
RoHS	compliant

**Suitable Cable**

RG316D, RD316

**Packing**

Single or 100