

SMA Plug (Male) Right Angle Connector Solder Attachment  
for .141, DC-12.4GHz, VSWR 1.25

**SMA1E59-0141A / 1QQ**

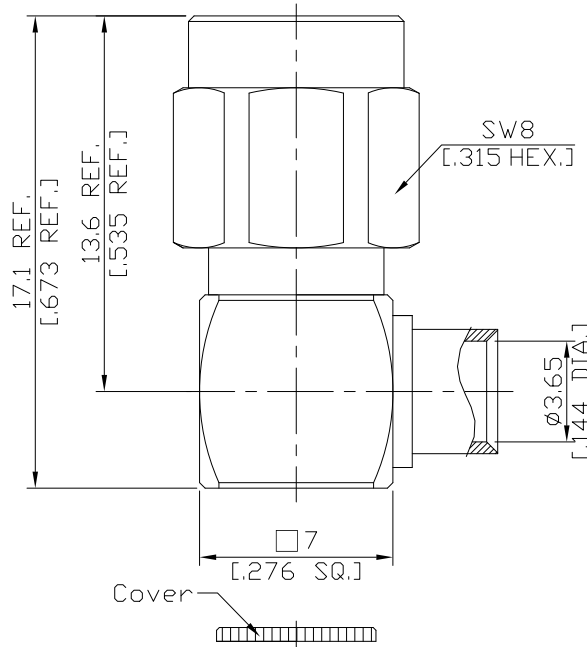

All dimensions are in mm [inch]

Tolerances according to DIN ISO 2768-mH

**Interface**

According to

IEC 60169-15; CECC 22110; MIL-PRF-39012; MIL-STD-348B/310; EN 122110

**Electrical Data**

Impedance	50 Ω
Frequency	DC to 12.4 GHz
VSWR (Return Loss)	≤ 1.25 (≥ 19.08 dB)
Insertion Loss	≤ 0.04 x √F (GHz) dB
Insulation Resistance	≥ 5 GΩ
Center Contact Resistance	≤ 3 mΩ
Outer Contact Resistance	≤ 2 mΩ
Test Voltage	1000 V rms
Working Voltage	480 V rms
Power handling (at 20 °C, sea level)	≤ 200 W @ 2 GHz

*-VSWR in application depends decisive on cable assembly process-*

**Material And Plating**

Piece Parts	Material	Plating
Centre contact	Brass	Gold plating (Non-magnetic nickel-phosphorus underplating)
Body	Stainless Steel	Gold plating (Non-magnetic nickel-phosphorus underplating)
Insulator	PTFE	
Gasket	Silicone Rubber	
Coupling nut	Stainless Steel	Gold plating (Non-magnetic nickel-phosphorus underplating)

SMA Plug (Male) Right Angle Connector Solder Attachment  
for .141, DC-12.4GHz, VSWR 1.25

**SMA1E59-0141A / 1QQ**

**Mechanical Data**

Coupling Mechanisms	Screw-Lock
Mating Cycles	≥ 500
Coupling Nut Retention	≥ 270 N
Center contact captivation: axial	≥ 20 N
Coupling Test Torque	≤ 1.7 Nm
Recommended Torque	0.8 Nm to 1.1 Nm
Centre Contact	Soldered
Cable Entry	Soldered

**Environmental Data**

Temperature Range	-65°C to +165°C
Thermal Shock	MIL-STD-202, Method 107, Condition B
Corrosion	MIL-STD-202, Method 101, Condition B
Vibration	MIL-STD-202, Method 204, Condition D
Shock	MIL-STD-202, Method 213, Condition I
Moisture Resistance	MIL-STD-202, Method 106
RoHS	Compliant

**Suitable Cables**

RSR-141, RSF-141, RSF-141-FEP, EF402, RG 402/U

**Packing**

Single or 100