

SMA Plug (Male) Straight Connector Crimp/Contact Pin Solder Attachment
for RG-316, DC-6 GHz, VSWR 1.15

SMA1C50-G316B / 144

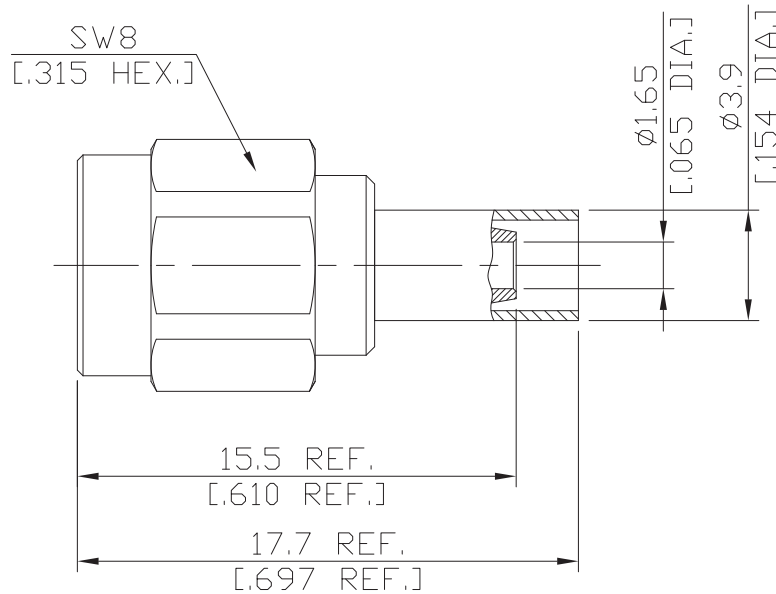

All dimensions are in mm [inch]
Tolerances according to DIN ISO 2768-mH

Interface

According to IEC 60169-15; CECC 22110; MIL-PRF-39012; MIL-STD-348B/310; EN 122110

Electrical Data

Impedance	50 Ω
Frequency	DC to 6 GHz
VSWR (Return Loss)	≤ 1.15 (≥ 23.13 dB)
Insertion Loss	≤ 0.04 x √F (GHz) dB
Insulation Resistance	≥ 5 GΩ
Center contact resistance	≤ 3 mΩ
Outer contact resistance	≤ 2 mΩ
Test Voltage (at sea level)	1000 V rms
Working Voltage (at sea level)	480 V rms
Power handling	≤ 200 W @ 2 GHz
RF Leakage	≥ 100 dB up to 1 GHz

*VSWR in application depends decisive on cable assembly process-

Material And Plating

Piece Parts	Material	Plating
Centre Contact	Brass	Gold plating (Non-magnetic nickel-phosphorus underplating)
Body	Brass	Copper-Tin-Zinc Alloy
Insulator	PTFE	
Gasket	Silicone Rubber	
Coupling Nut	Brass	Copper-Tin-Zinc Alloy
Crimp ferrules	Brass	Copper-Tin-Zinc Alloy

SMA Plug (Male) Straight Connector Crimp/Contact Pin Solder Attachment
for RG-316, DC-6 GHz, VSWR 1.15

SMA1C50-G316B / 144

Mechanical Data

Coupling mechanisms	Screw-On
Mating Cycles	≥ 500
Coupling Nut Retention	≥ 270 N
Centre contact	Soldered
Cable entry	Crimped
Center Contact Captivation: axial	≥ 27 N
Coupling Test Torque	max. 1.70 Nm
Recommended Torque	0.57 Nm

Environmental Data

Temperature Range	-65°C to +165°C
Thermal shock	MIL-STD-202, Method 107, Condition B
Corrosion	MIL-STD-202, Method 101, Condition B
Vibration	MIL-STD-202, Method 204, Condition D
Shock	MIL-STD-202, Method 213, Condition I
Moisture Resistance	MIL-STD-202, Method 106
RoHS	compliant

Suitable Cable

RG-316, RG-174, RG-188

Packing

Single or 100