

BNC Jack (Female) Straight Connector Crimp/Contact Pin Solder or Crimp Attachment for RG179, DC-1 GHz, VSWR,1.25

**BNC2C70-G179A / H3**

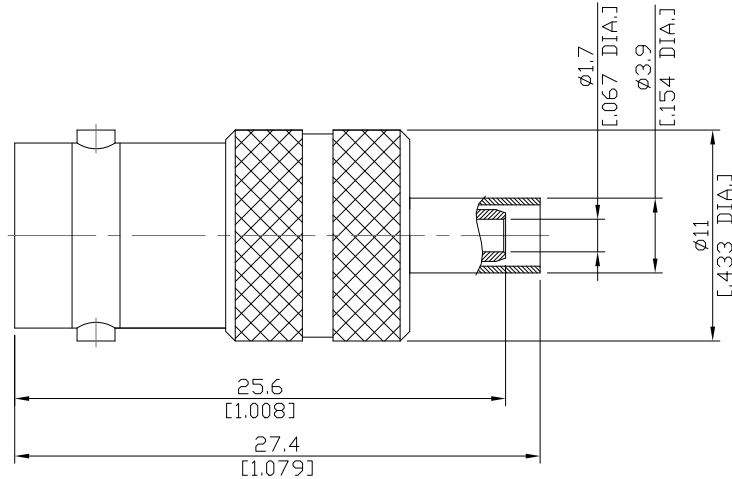

All dimensions are in mm [inch]

Tolerances according to DIN ISO 2768-mH

**Interface**

According to

MIL-STD-348B/330; IEC 61169-8; MIL-PRF-39012; CECC 22120

**Electrical Data**

Impedance	75 Ω
Frequency	DC to 1 GHz
VSWR (Return Loss)	≤ 1.25 (≥ 19.08 dB)
Insertion Loss	≤ 0.05 × √F (GHz) dB
Insulation Resistance	≥ 5 GΩ
Center contact resistance	≤ 1.5 mΩ
Outer contact resistance	≤ 1 mΩ
Test Voltage (at sea level)	1500 V rms
Working Voltage (at sea level)	400 V rms
Power handling	≤ 80 W @ 2 GHz

-VSWR in application depends decisive on cable assembly process-

**Material And Plating**

Piece Parts	Material	Plating
Centre Contact	Phosphor Bronze	Gold plating (Non-magnetic nickel-phosphorus underplating)
Body	Brass	Nickel
Insulator	PTFE	
Crimp ferrules	Brass	Nickel

**BNC Jack (Female) Straight Connector Crimp/Contact Pin Solder or Crimp Attachment for RG179, DC-1GHz, VSWR,1.25**

**BNC2C70-G179A / H3**

**Mechanical Data**

Coupling mechanisms	Bayonet-Lock
Mating Cycles	min. 500
Centre contact	Soldered or Crimped
Cable entry	Crimped
Center Contact Captivation: axial	≥ 15 N

**Environmental Data**

Temperature Range	-65°C to +165°C
Thermal shock	MIL-STD-202, Method 107, Condition B
Corrosion	MIL-STD-202, Method 101, Condition B
Vibration	MIL-STD-202, Method 204, Condition B
Shock	MIL-STD-202, Method 213, Condition G
Moisture Resistance	MIL-STD-202, Method 106
RoHS	compliant

**Suitable Cable**

RG 179, RG187

**Packing**

Single or 100